



- Works without electrical current
- Mechanical stroke adjustment
- Space-saving design
- Separate air bleeding
- High reliability due to teflon compound diaphragm
- Optional with integrated solenoid valve



Pneumatic metering pump incl. control by external 3/2-port directional control valve
 optional

Pneumatic metering pump incl. control by integrated 3/2-port solenoid valve

Due to its very compact construction the pneumatic metering pump is recommended especially for the use in very cramped circumstances. All operational components are arranged at the front side of the pump.

The diaphragms are controlled by pressurized air of a driving piston. When the pressurized air or turn-over to the 3/2-port directional control valves get switched-off the diaphragms turn back to the initial position by a spring. The repressed volume is

delivered to the diaphragm chamber over a double ball suction and pressure valve. The delivery performance can be controlled exactly by stroke frequency and a lock-type stroke adjustment. The pump can be synchronized manually for start-up or venting during an upcoming air pressure.

A continuous metering demands a synchronized control by an external or internal 3/2-port directional control valve.



Technical Data:

Mechanical Data:

Pump capacity [l/h]:	3.0	6.0	12.0
Metering back-pressure [bar]:	6	6	6
Delivery capacity per stroke [cm ³]:	0.45	0.83	1.67
Suction height:	1.5 mWs		
Metering frequency max:	120 1/min		
Air consumption [l/h]:	< 80 *		
Air control pressure [bar]:	7		
Suction valve :	without spring 2 balls		
Pressure valve :	each ball spring loaded		
Weight [kg]:	approx. 0.5		

* at 100% stroke setting and max. metering frequency

Material:

Control block:	polyamide
Pump head:	polypropylene
Diaphragm:	PTFE - EPDM compound diaphragm
Valve body:	polypropylene
Seals:	FPM 602 (Viton B) ** either EPDM
Valve balls:	stainless steel 1.4401 ** either Duran glass
Return spring:	stainless steel (1.4310)
Colour:	blue RAL 5007 / black

** Standard

Electrical Data:

(integrated solenoid valve)

Power supply:	24 V DC other voltage on request
Power:	7 W
Protection class:	IP 65 when using wiring outlet
Operating factor:	100 %
Clocking:	T _{on} / T _{off min} 240/240 msec

Dimensions:
 (pneumatic metering pump with external 3/2-port directional control valve)

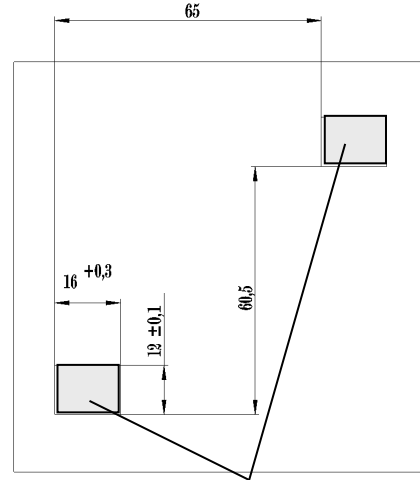
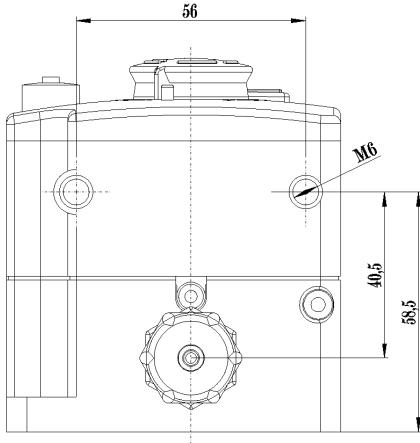

Cut-out for bayonet locking unit
 (see also spare parts Pos. 15 - 17)

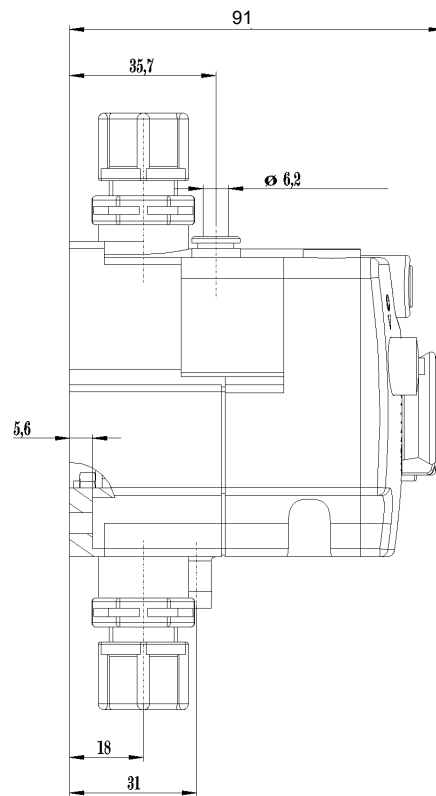
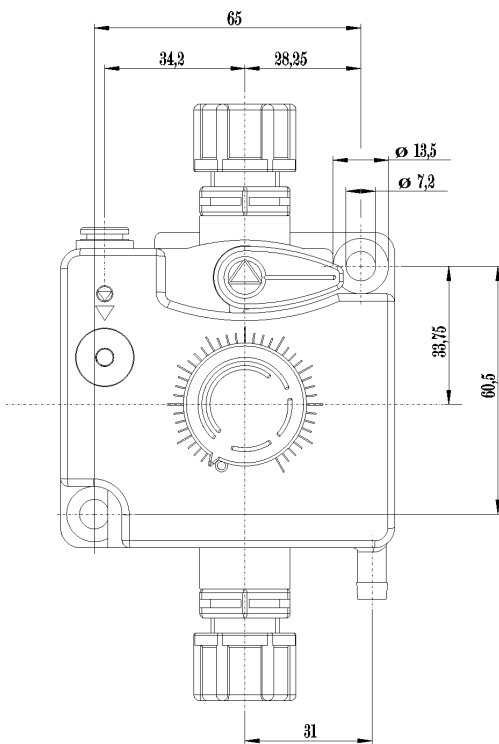

Hose connections

- Suction connection (int.Ø/ext.Ø): 4/6, 6/8, 6/12 mm
- Pressure connection (int.Ø/ext.Ø): 4/6, 6/8, 6/12 mm
- Venting: for hose PVC-soft ID6
- Compressed-air supply: for pipe PE/PA AD6

Dimensions:
 (pneumatic metering pump with integrated 3/2-port solenoid valve)

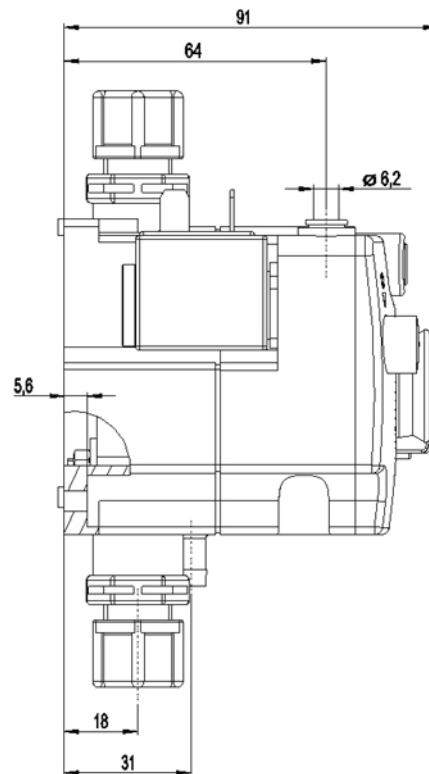
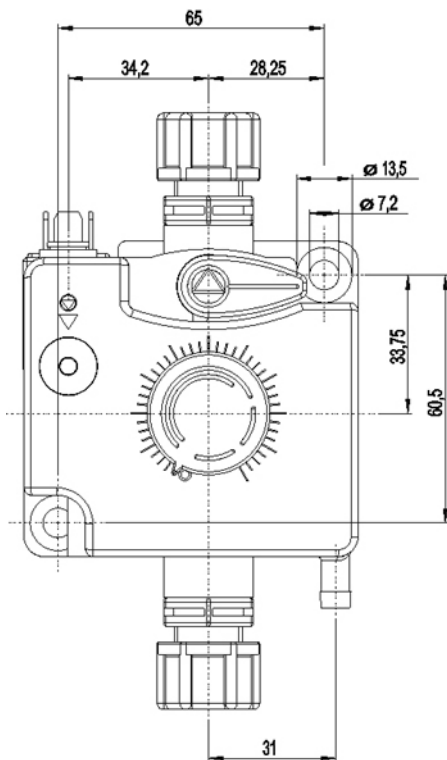
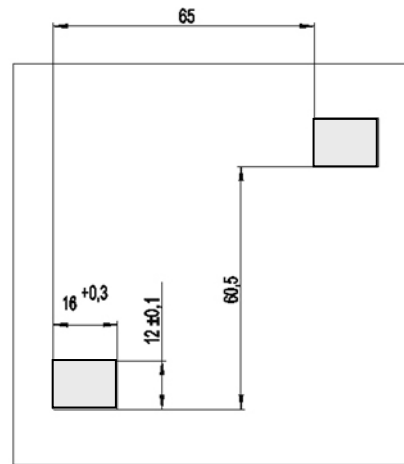
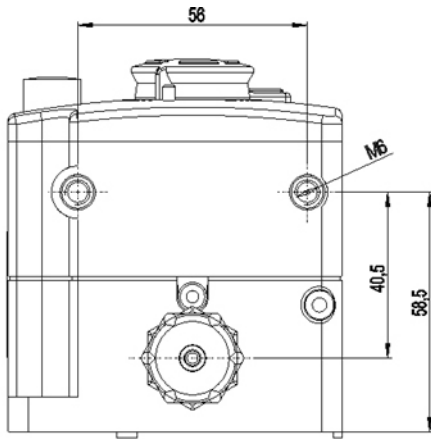

Hose connections

- Suction connection (int.Ø/ext.Ø): 4/6, 6/8, 6/12 mm
- Pressure connection (int.Ø/ext.Ø): 4/6, 6/8, 6/12 mm
- Venting: for hose PVC-soft ID6
- Compressed-air supply: for pipe PE/PA AD6



Pump code – part 1

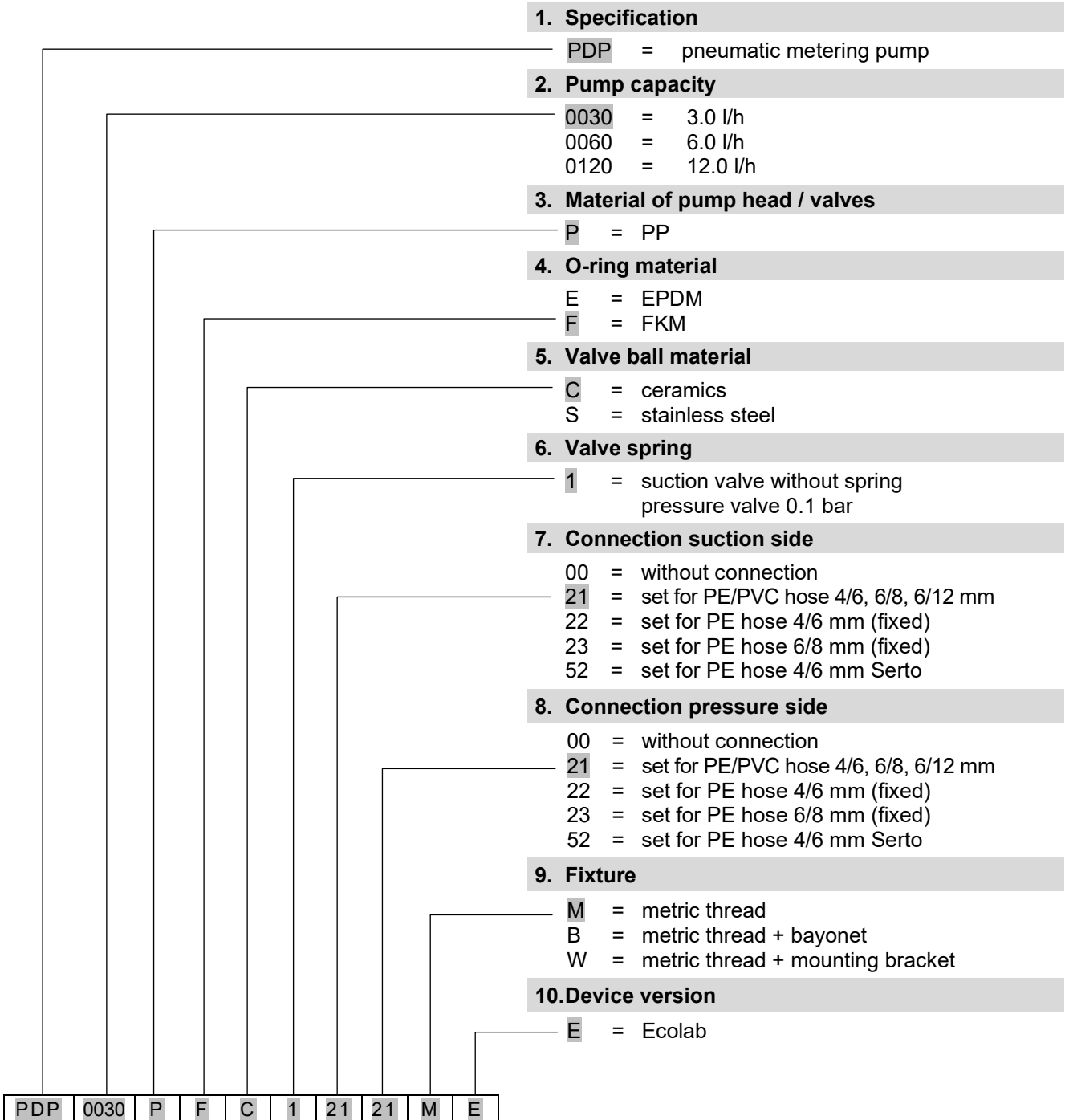



Pump code – part 2

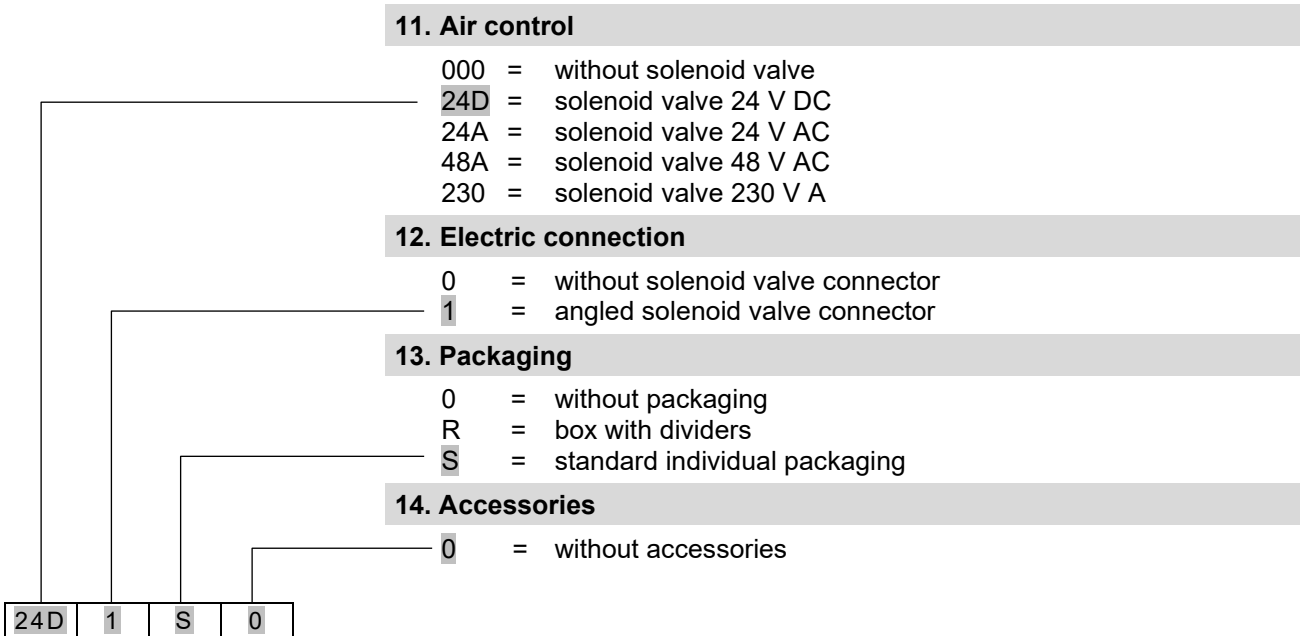

Other versions on request!

Example of a complete pump code:

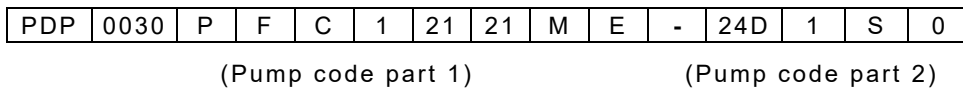

Ordering Data:

Article	Pump code	Material No.
Pneumatic metering pump		
Version with external 3/2-port directional control valve		
	PDP-0030-PFS1-2121-ME-0000-R0	141048
	PDP-0060-PFS1-2121-ME-0000-R0	on request
	PDP-0120-PFS1-2121-ME-0000-R0	141049
Version with integrated 3/2-port solenoid valve		
	PDP-0030-PFS1-2121-ME-24D1-R0	141046
	PDP-0060-PFS1-2121-ME-24D1-R0	141050
	PDP-0120-PFS1-2121-ME-24D1-R0	141047

Extent of supply: Hose connection material 4/6, 6/8 und 6/12 mm